

COMBITHERM® CTP7-20G GAS BOILER-FREE



CAPACITY

- Eight (8) full-size sheet pans; eight (8) GN 2/1 pans; sixteen (16) full-size or GN 1/1 pans, two rows deep
- Two (2) side racks with eight (8) non-tilt support rails; 19-7/8" (505mm) horizontal width between rails, 2-3/4" (70mm) vertical spacing between rails

CONSTRUCTION

- Stainless steel exterior, bright annealed interior
- Seamless welded interior stainless steel cavity
- CoolTouch3™ triple pane window door with hinged inner glass prevents additional heat loss and increases cooking efficiency
- Door is hinged right with a 130° swing
- High efficiency LED lighting integrated in the door

- Door mounted self-draining drip tray
- Hands free positive catch door handle with lighted visual alerts [PATENT PENDING]
- PROrinse™ ergonomic retractable hand shower includes a safety shutoff interlock that shuts off water to the hose [PATENT PENDING] and a built-in backflow preventer in the hand shower handle
- SafeVent™ provides automatic steam venting at the end of the cooking cycle [PATENT #7,282,674]
- Zero Clearance design maximizes floor space utilization with features that carefully protect temperature sensitive components and controls [PATENT PENDING]
- Adjustable stainless steel legs provide stability
- High efficiency modulating gas burner maximizes the residence time of flue gases [PATENT PENDING]

CT PROFORMANCE – STANDARD FEATURES

- Oven with state-of-the-art innovative solutions that meld together perfectly to deliver the highest performance standards, consistent food quality, and production efficiency.
- PROtouch™ control provides a simple and intuitive touch screen interface, large screen display and icons that are easy to use and identify.
- Software operation in English, French, German, Korean, Mandarin, Russian, or Spanish.
- Four cooking modes:
Steam - 85°F to 250°F (30°C to 120°C)
Convection - 85°F to 575°F (30°C to 301°C)
Combination - 85°F to 575°F (30°C to 301°C)
Retherm - 245°F to 320°F (120°C to 160°C)
- Cook time is displayed in hours : minutes : seconds for greater precision.

- Access an unlimited number of programmed titled recipes that you've customized, marked as favorites, or placed into category folders.
- Removable, single-point, quick-connect, core temperature product probe.
- Three power levels: reduced power to manage kitchen power peaks, eco power for optimal oven efficiency, and PROpower™ - an accelerated turbo power for an instant boost of heat or quick heat recovery [PATENT PENDING].
- Absolute Humidity Control™ (AHC) provides 0-100% humidity levels allowing more control over the ideal cooking environment and product finish [PATENT PENDING].
- Auto-reversing fan with five different fan speeds expands cooking capabilities - from braising, roasting, to flow sensitive products such as soufflés and meringues, or any product affected by a high velocity of air movement.
- Moisture injection feature provides perfect sheen and crust on breads and pastry items.

- Auto-detect USB for HACCP data access, Recipe Management, and software updates.
- Multi-shelf timers can be labeled by product name and programmed in hours, minutes and seconds giving greater control for delicate items.
- Sleep mode can be used to save valuable time by eliminating the need to power down and restart.
- Low temperature Delta-T feature for lower temperature cooking or longer term roasting.
- Programmable cool down feature provides the operator with the ability to lower the temperature of the oven compartment at an accelerated pace.
- Dehydration auxiliary function.
- CombiClean PLUS™ fully automated cleaning with 5 cleaning levels.
- Odometer tracking and audit trail provides extensive diagnostic and troubleshooting features.

SHORT FORM SPEC

Provide Alto-Shaam Combitherm® CT PROformance™ countertop model CTP7-20G boiler-free gas CombiOven designed with EcoSmart® technology for reduced energy and water consumption. Includes operational modes for steam, convection, a combination of steam and convection heat, and retherm. Oven is to be constructed of 18 gauge stainless steel interior cavity. Oven includes an attached retractable hand shower spray hose with safety shutoff interlock system and a backflow preventer. PROtouch™ control

features include a cool-down function, automatic cleaning function, recipe programming, three power levels, 0-100% humidity levels, auto-reversing fan with five (5) fan speeds, multi-shelf timers, and sleep mode. Oven includes USB port, HACCP data access, and four (4) adjustable stainless steel legs. Each oven is to accommodate up to eight (8) full-size sheet pans or sixteen (16) full-size hotel pans (GN 1/1), include standard right-hand door hinging, eight (8) non-tilt support rails, and four (4) stainless steel shelves.

FACTORY INSTALLED OPTIONS

Electrical Choices

- 120V 1ph 208-240V 1ph
 208-240V 3ph 380-415V 3ph

Gas Type

- Natural Propane

Door Swing

- Right-hand Door Hinging, standard
 Recessed Door, optional; increases oven width by 5" (127mm)

- Extended One-year Warranty

- Automatic Grease Collection System [U.S. PATENT 8,997,730 B2], includes four (4) 6-piece, self-trussing poultry racks #5014438, interior drip collection pan, and grease collection container with shut off valve

Cleaning system choices

- Automatic tablet-based cleaning system, standard
 Automatic liquid cleaning system pumps through the system for a deep cleaning, hands free process, includes one (1) removable support tray for liquid cleaner container, optional

- CombiLatch™ door interlock with adjustable timer safeguards operators from heat and steam in the oven cavity when opening the door during a cooking cycle

Installation Options (CHOOSE ONLY ONE)

- Alto-Shaam Combitherm Factory Authorized Installation Program - AVAILABLE IN THE U.S. AND CANADA ONLY
 Installation Start-Up Check - AVAILABLE THROUGH AN ALTO-SHAAM AUTHORIZED SERVICE AGENCY
 Smoking Feature - including one-step cold smoking (NOT AVAILABLE ON UNITS WITH SECURITY DEVICES)

Probe Choices

- Removable, single-point, quick-connect core temperature probe, standard
 Removable, single-point, quick-connect sous vide temperature probe, optional
 Hard-wired, multi-point core temperature probe, optional

Security Devices for correctional facility use

- Optional base package (not available with recessed door): Includes tamper-proof screw package and secured door glass, excludes temperature probe
 Anti-entrapment device, optional
 Control panel security cover, optional
 Hasp door lock (padlock not included), optional
 Removable, single-point, quick-connect core temperature probe, optional

- Seismic feet package, optional

- Stacking Hardware

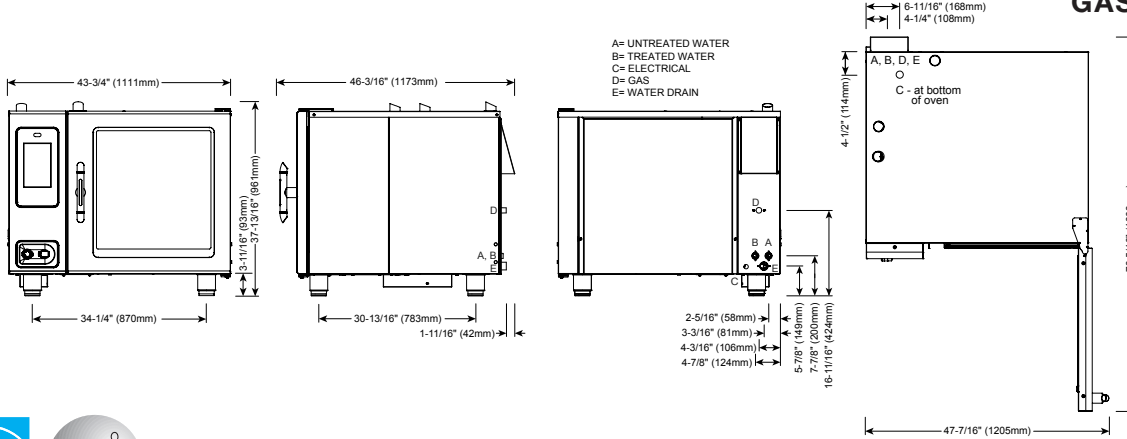

DIMENSIONS: H x W x D	
EXTERIOR:	37-13/16" x 43-3/4" x 46-3/16" (961mm x 1111mm x 1173mm)
EXTERIOR WITH RECESSED DOOR:	37-13/16" x 48-3/4" x 46-3/16" (961mm x 1238mm x 1173mm)
INTERIOR:	23-1/4" x 24-1/4" x 32-3/4" (590mm x 616mm x 832mm)

WATER REQUIREMENTS	
TWO (2) COLD WATER INLETS - DRINKING QUALITY	
ONE (1) TREATED WATER INLET: 3/4" NPT*	* Both inlets can be from same 3/4" source. Divide using a manifold. Run one side through treatment device before running to oven.
ONE (1) UNTREATED WATER INLET: 3/4" NPT*	
LINE PRESSURE: 30 psi minimum dynamic and 90 psi maximum static (200 to 600 kPa)	
WATER DRAIN: 1-1/2" (40mm) CONNECTION WITH A VERTICAL VENT TO EXTEND ABOVE THE EXHAUST VENT. MATERIALS MUST WITHSTAND TEMPERATURES UP TO 200°F (93°C).	
CLEARANCE REQUIREMENTS	
LEFT: 0" (0mm)	18" (457mm) RECOMMENDED SERVICE ACCESS
RIGHT: 0" (0mm) NON-COMBUSTIBLE SURFACES	2" (51mm) DOOR SWING OR COMBUSTIBLE SURFACES
TOP: 20" (508mm) FOR AIR MOVEMENT	
BACK: 4" (102mm)	BOTTOM: 5-1/8" (130mm) FOR LEGS, AIR INTAKE
4-5/16" (109mm) OPTIONAL PLUMBING KIT	
INSTALLATION REQUIREMENTS	
• Oven must be installed level.	• Hood installation is required.
• Water supply shut-off valve and back-flow preventer when required by local code.	

WATER QUALITY STANDARDS	
It is the sole responsibility of the owner/operator/purchaser of this equipment to verify that the incoming water supply is comprehensively tested and if required, a means of "water treatment" provided that would meet compliance requirements with the published water quality standards shown below. Non-compliance with these minimum standards will potentially damage this equipment and/or components and void the original equipment manufacturer's warranty. Alto-Shaam recommends using OptiPure® [www.optipurewater.com] products to properly treat your water.	
Contaminant	Inlet Water Requirements
Free Chlorine	Less than 0.1 ppm (mg/L)
Hardness	30-70 ppm
Chloride	Less than 30 ppm (mg/L)
pH	7.0 to 8.5
Silica	Less than 12 ppm (mg/L)
Total Dissolved Solids (tds)	50-125 ppm

GAS REQUIREMENTS (GAS TYPE MUST BE SPECIFIED ON ORDER)	
HOOK-UP: 3/4" NPT	
RATED THERMAL LOAD	
NORTH AMERICA	INTERNATIONAL
Natural Gas/Propane	G20, G25, G31
Gross Heating Value (HHV)	Net Heating Value (LHV)
98,000 Btu / hr	26.5 kW
CONNECTED PRESSURE	
NORTH AMERICA	INTERNATIONAL
Natural Gas	Propane
Minimum: 5.5" W.C. dynamic	Minimum: 9" W.C. dynamic
Maximum: 14" W.C. static	Maximum: 14" W.C. static
G20	20mbar (2kPa)
G25	20mbar (2kPa)
G31	30mbar (3kPa)

ELECTRICAL - CTP7-20G (DEDICATED CIRCUIT REQUIRED)						WITH COMBISMOKER® OPTION							
	VOLTAGE	PH	HZ	AWG	CONNECTION no cord, no plug	AMPS	BREAKER	kW		CONNECTION no cord, no plug	AMPS	BREAKER	kW
☐	120	1	60	14	L1, N, G	6.8	20	.84	☐	L1, N, G	12.0	20	1.5
☐▲	208 - 240	1*	50/60	14	L1, L2/N, G	4.8 - 4.2	15	1.0	☐▲	L1, L2/N, G	7.3 - 7.1	15	1.5 - 1.7
☐▲	208 - 240	3	50/60	14	L1, L2, L3, G	4.8 - 4.2	15	1.0	☐▲	L1, L2, L3, G	7.3 - 7.1	15	1.5 - 1.7
☐▲	380 - 415	3	50/60	14	L1, L2, L3, N, G	4.6 - 4.2	15	1.0	☐▲	L1, L2, L3, N, G	7.2 - 7.1	15	1.6 - 1.7

* NORTH AMERICA VOLTAGE CHOICE ⚡ GROUND FAULT OR RESIDUAL CURRENT PROTECTION DEVICE MUST ACCOMMODATE A LEAKAGE CURRENT OF 20mA ☐ INTERNATIONAL VOLTAGE CHOICE * ELECTRICAL SERVICE CHARGE APPLIES
▲ PER UL REQUIREMENTS, MUST BE PERMANENTLY CONNECTED TO ELECTRICAL SUPPLY SOURCE

